

ADAstra 19" EQUIPMENT RACKS

adastra

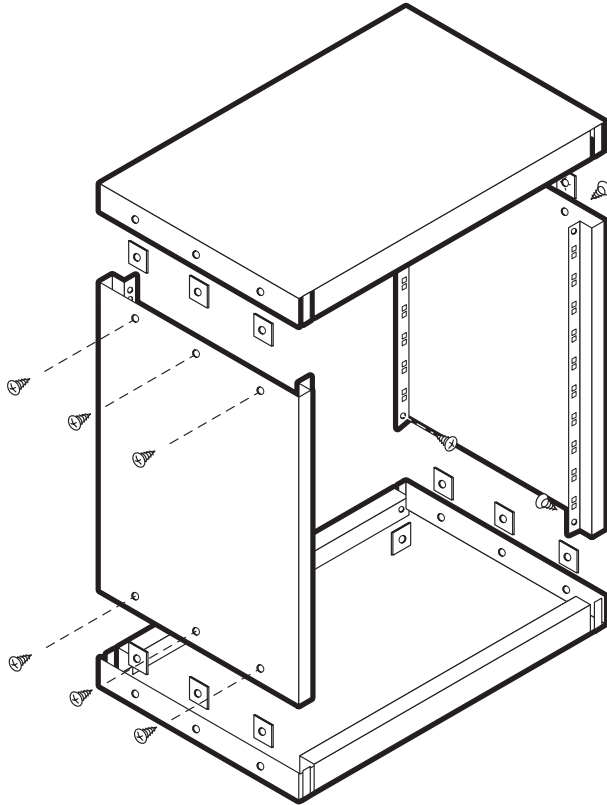

CABINET ASSEMBLY INSTRUCTIONS

Please check component quantities are correct before assembly :

- 1 x Top panel
- 1 x Bottom panel
- 2 x Side panels
- 20 x Spire clips
- 20 x Self-tap screws

1. Drill holes for handles on relevant panels before assembly, taking care to protect outer surface from any swarf damage.
2. Attach spire clips as illustrated in the diagram ensuring the flat side is on the outer surface.
3. Place the top upside down on a flat surface and fix the side panels as shown in the diagram. The side panels overlap both top and bottom panels. The small tongues located at the four corners of both top and bottom panels fit inside the channel section of the side panels.
4. Align and fasten the 4 inner corner fixing screws.
5. Attach the base to the side panels, align and secure the corner fixings.
6. If required, a lockable door can be fitted using the 4 screws supplied. Hold the spire clips behind the front edge and locate the screws through the door hinges and secure. Ensure the door alignment is correct before fully securing.

NOTE: Do not over-tighten the fixing screws to prevent damage to either screws or spire clips. To ease assembly use a small awl to align the spire clips with fixing holes.